

CANTER

FUSO

CANTER 815

4X2 / WIDE CAB / MANUAL OR DUONIC DCT



**OUR SAFEST CANTER EVER WITH AEBS, LDWS AND ESP STANDARD.
CLASS LEADING 30,000KM SERVICE INTERVALS.**

GVM

7,500_{KG}

GCM

11,000_{KG}

Power/Torque

110_{kW} / 370_{Nm}

- Light rigid licence required. Can be derated and driven with a passenger car licence.
- Actual product may vary from image shown.

CANTER SPECIFICATIONS

MODEL

A	4X2 815 WIDE CAB MWB 6 SP. DUONIC AMT (FEC71ER3SFBG)
B	4X2 815 WIDE CAB LWB 6 SP. DUONIC AMT (FEB71GR3SFBG)
C	4X2 815 WIDE CAB MWB 5 SP. MAN (FEC71ER4SFBG)
D	4X2 815 WIDE CAB LWB 5 SP. MAN (FEB71GR4SFBG)

WHEEL BASE

3400mm
3850mm
3400mm
3850mm

GVM (optional)

7,500kg (4,495kg)
7,500kg (4,495kg)
7,500kg (4,495kg)
7,500kg (4,495kg)

GCM (optional)

11,000kg (7,995kg)
11,000kg (7,995kg)
11,000kg (7,995kg)
11,000kg (7,995kg)

Engine	
Engine Version	FUSO 4P10-T4 Diesel
Configuration	4 Cyl. In-line DOHC, 4-Valve
Injection System	Bosch Common Rail Direct Injection Bosch Piezo Technology Injectors
Type	Variable Geometry Turbo Charged Air to Air Intercooled
Displacement	3 litre (2998cc)
Bore	95.8mm
Stroke	104mm
Power (DIN)	110kW @ 2840~3500 rpm
Torque (DIN)	370Nm @ 1350~2840 rpm
Maximum Engine Speed	4100 rpm
Compression Ratio	17.5:1
Cooling System / Oil Cooler	Water cooled, 13.7L capacity/ Plate type engine oil cooler
Air Cleaner	Paper Element Type with Restrictor Indicator. Vertical Intake Mounted on Clean Air Side (RH)
Emission Control	Diesel Particulate Filter (DPF) Exhaust Dash Display DPF Status 0~9 (Empty~Full) Parked Regeneration possible from 7~9
Emission Level	ADR 80/03 - Euro 5

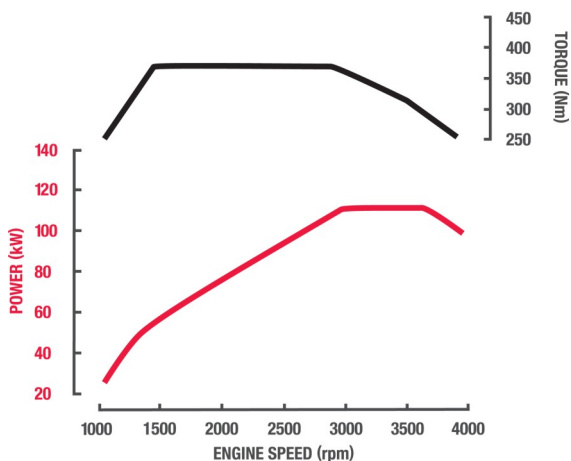

Fuel	
Tank Type	Rectangular Steel Tank with Locking Cap
Fuel Capacity *	100 Litres
Filtration	Filter with Water Separator and Indicator Sensor
Notes	*Max Fill to approx 95% of capacity

Cooling	
Fan Drive	Thermo modulated continuous control (Viscous)
Radiator	Corrugated Fin with Expansion Tank

Electrical	
Voltage	12V Negative Earth
Battery Capacity	2x12V, 70Ah/5hr
Battery Specification	115D31L x2
Headlamp Type	LED
Body Builder Harness	Yes

Clutch		
Clutch Model	A B Fully Automated Dual Clutch (no clutch pedal)	C D FUSO C4W30
Type	A B Dual Clutch (Wet Multi-plate)	C D Single Dry Plate, Direct Hydraulic Type

Transmission		
Version	A B FUSO DUONIC M038S6	C D FUSO M038S5
Type/Speeds	A B 6 Speed Dual Clutch with Auto and Manual Modes	C D 5 Speed with In-Dash Gearshift Lever
Features	A B Virtually Instant Gear Changes In-Dash Gear Lever with Park Brake Position ECO Mode to Minimise Fuel Usage	C D Synchromesh 1st-5th
Ratios	A B 1st: 5.397 2nd: 3.788 3rd: 2.310 4th: 1.474 5th: 1.000 6th: 0.701 Rev. 5.397	C D 1st: 5.494 2nd: 3.038 3rd: 1.592 4th: 1.000 5th: 0.723 Rev. 5.494
PTO Opening	LH Side	

Front Axle	
Axle Version	FUSO F350T
Type	Reverse Elliot 'I' Beam
Capacity *	3100kg
Notes	*See MAX LOADING for vehicle capacity.

Front Suspension	
Type	Multi-Leaf with Stabiliser Bar and Double Acting Shock Absorbers
Size	1150x70mm Leaves

Rear Axle		
Type	Full Floating Banjo Type	
Axle Version	FUSO R035T	
Capacity*	6000kg	
Ratio	A B 5.714:1	C D 5.285:1
Notes	*See MAX LOADING for vehicle capacity.	

Rear Suspension	
Type	Steel Suspension
Details	Semi-Elliptic Leaf with Stabiliser Bar and Double Acting Shock Absorbers
Size Main Leaves	1250x70mm
Size Helper Leaves	880x70mm

Max Loading	
Front	3100kg
Rear	6000kg
Total	7500kg

Options	
Options	H31: 4495/7995kg GVM/GCM Rating

Steering	
Type	Integral Ball and Nut Type
Steering Column	Tilt/Telescopic Adjustable
Power Assist	Standard



CANTER SPECIFICATIONS

MODEL

A	4X2 815 WIDE CAB MWB 6 SP. DUONIC AMT (FEC71ER3SFBG)
B	4X2 815 WIDE CAB LWB 6 SP. DUONIC AMT (FEB71GR3SFBG)
C	4X2 815 WIDE CAB MWB 5 SP. MAN (FEC71ER4SFBG)
D	4X2 815 WIDE CAB LWB 5 SP. MAN (FEB71GR4SFBG)

WHEEL BASE

3400mm
3850mm
3400mm
3850mm

GVM (optional)

7,500kg (4,495kg)
7,500kg (4,495kg)
7,500kg (4,495kg)
7,500kg (4,495kg)

GCM (optional)

11,000kg (7,995kg)
11,000kg (7,995kg)
11,000kg (7,995kg)
11,000kg (7,995kg)

Brakes	
Type	Hydraulic Dual Circuit with Front and Rear Discs Twin Calliper Front and Rear
Size Front	A 235x40mm B C 252x40mm D 310x40mm
Size Rear	A B C 252x40mm D 310x40mm
Features	ABS plus EBD (Electronic Brake Distribution) Active Emergency Braking System (AEBS) Electronic Stability Program (ESP) Exhaust Brake Brake Priority System Electronic Brake Wear Sensors (From Aug 20 build)
Park Brake	Transmission Mounted

Wheels & Tyres	
Wheel Type	7 x Single Piece Disc Rims (Including Spare)
Wheel Size	17.5x6.0-127
Wheel Stud Pattern	6 Stud 222.25 PCD
Tyre Size All	215/75R17.5 124/123
Spare Tyre Carrier	Provided

Chassis	
Type	Reinforced Tapered Channel
Size	A C 212x65x6mm B D 192x60x6mm
Width	A C 850mm B D 752mm
Tensile Strength	A C 540 MPa B D 440 MPa

Instruments	
Gauges	Speedometer with Odometer Tachometer Fuel Level Water Temperature
Colour Information Display	Fuel Consumption DPF Bar Chart from 1-9 Water Temperature Lane Departure Warning Maintenance Reminder System Tripmeters

Multi-Media Package	
Satellite Navigation	Maps with heavy vehicle weight, length, height & hazardous material selectable restrictions with 3 years of Map updates
Colour Display	8 inch LCD with touch screen control
Phone Connectivity	Bluetooth® hands free + phone mirroring.
Audio Visual Entertainment	Bluetooth® music streaming compatible Digital radio DAB+ (also AM/FM for areas not covered by DAB+) & USB
Reversing Camera Compatible	1 Reverse Camera fitted as standard Display can accept up to 5 additional cameras#
Optional Accessories (available at additional cost)	Rear Mounted Parking Sensor Kit High or Low Tyre Pressure Monitoring System
Notes	# Cameras available through spare parts

Standard Features	
Airbag(s)	Dual Air Bags and Seat Belt Pre-Tensioners (Driver & Far Side Passenger)
Active Safety Features	ABS plus Electronic Brake force Distribution (EBD) Advanced Emergency Braking (AEBS) Anti-Slip Regulator (ASR) Electronic Stability Program (ESP) Lane Departure Warning System (LDWS)
Cruise Control	A B Yes C D No
Hill Start System	Yes
Cab Cooling & Heating	Air Conditioner / Heater / Demister
Accessory Power	12V Accessory Power Outlet / Cigar Lighter
Driving	Fuso Multimedia Unit Keyless Central Locking Electric Windows Cup Holders 2 3 seats
Storage	Dual Overhead Storage Pockets In-Dash Centre Document Storage Door Storage Pockets Dash Storage Tray (1 DIN) Coat Hooks
Cab: External	Front End-Outline Marker Lamps Door Side Impact Beams
Chassis	Reverse Warning Buzzer Factory Reverse Camera with Infrared Display and Audible Pickup (Supply only in Cabin with Cab Chassis)

Cab Features	
Cab Structure	ECE-R29 European Cab Strength Approved
Mounting	Hydroelastic 4 Point
Additional Engine Access	A B Removable Engine C D Access Panel N/A
Colour	Natural White
Windscreen Wipers	2 Speed + Intermittent Cycle with Integrated Washer Nozzles
Rear Vision Mirrors	1 x Internal 2 x External Convex (ECE 46) - Heated
Seating Capacity	3
Seat Belts	Lap Sash Belts for Outside Seating Positions Lap Belt for Centre Seat Driver Seat Belt Warning
Seat (driver)	Suspended with Weight Adjustment, LH Arm Rest and Lumbar Support
Seats (passenger)	Flat Folding, 2 Passenger Bench

Service Intervals	
Interval*	30,000km or 12 Months (whichever occurs first)

Warranty	
Basic/Powertrain	5 Years or 200,000kms (whichever occurs first)
Cab Perforation/Anti Corrosion	5 Years
Notes	* based on normal operating conditions and may be reduced when operating under severe conditions.

Performance	
Turning Circle (kerb to kerb - metres)	A C 12.2 B D 13.6
Road Speed (km/h) at Max Engine Speed	A 127 B 128 C D 130
Engine Speed (rpm) at 100km/hr (top gear)	A B 2817 C D 2687
Gradeability at Rated GVM (theoretical)*	A B 34.5% C D 32%
Notes	*This is theoretical performance only. Actual performance may vary under different conditions

CANTER SPECIFICATIONS

MODEL

A	4X2 815 WIDE CAB MWB 6 SP. DUONIC AMT (FEC71ER3SFBG)
B	4X2 815 WIDE CAB LWB 6 SP. DUONIC AMT (FEB71GR3SFBG)
C	4X2 815 WIDE CAB MWB 5 SP. MAN (FEC71ER4SFBG)
D	4X2 815 WIDE CAB LWB 5 SP. MAN (FEB71GR4SFBG)

WHEEL BASE

3400mm
3850mm
3400mm
3850mm

GVM (optional)

7,500kg (4,495kg)
7,500kg (4,495kg)
7,500kg (4,495kg)
7,500kg (4,495kg)

GCM (optional)

11,000kg (7,995kg)
11,000kg (7,995kg)
11,000kg (7,995kg)
11,000kg (7,995kg)

Mass estimated*

Front*	A D	B	C	
	1595kg	1610kg	1580kg	
Rear*	A B	C D		
	835kg	830kg		
Total*	A	B	C	D
	2430kg	2445kg	2410kg	2425kg
Notes	* Mass (est.) includes oil and water but excludes spare wheel, tools & fuel. Weights provided are subject to 3.5% variation (+/-)			

Dimensions mm

WFF (Width Front Fender) (mm)	1995			
WRA (Width Rear Axle) (mm)	A C	B D		
	2144	2034		
WRT (Width Rear Track) (mm)	A C	B D		
	1670	1560		
Width Frame (mm)	A C	B D		
	850	752		
A - Length Overall (mm)	A C	B D		
	5935	6685		
C - Front Overhang (mm)	1140			
D - Wheelbase (mm)	A C	B D		
	3400	3850		
G - Front Axle to Rear of Cab (mm)	525			
H - Rear of Cab to Rearmost Item Behind Cab (mm)	A B	C D		
	50	81		
I - Rearmost Item Behind Cab to Rear Axle (mm)	A	B	C	D
	2825	3275	2794	3244
J - Frame, Rear Axle to End (mm)	A C	B D		
	1395	1695		
P - Height Cab to Ground (mm)	A C	B D		
	2190	2180		
Q - Height Cab to Frame (mm)	A C	B D		
	1505	1514		
R - Height Rear Frame to Ground (mm)	A C	B D		
	807	797		

Body Builder's Notes

Notes	Chassis reinforcement must be utilised for Tipper/Demountable type body configurations. To conform with ADR 13/00 and 14/02 (lighting/mirror requirements) the following must be adhered to at body installation. - If overall width exceeds 2.1 metres and other than flat type or tipper body is fitted, rear end-outline markers must be installed. - If overall length exceeds 6.0 metres, side reflectors must be installed. - If overall length exceeds 7.5 metres and width exceeds 2.1 metres, side marker lamps must be installed. - If overall width is less than 2.2 metres, the mirrors must be modified to project not more than 230mm. To conform with ADR 42/04 (General Safety), rear wheel guards must be fitted to the vehicle.
-------	---

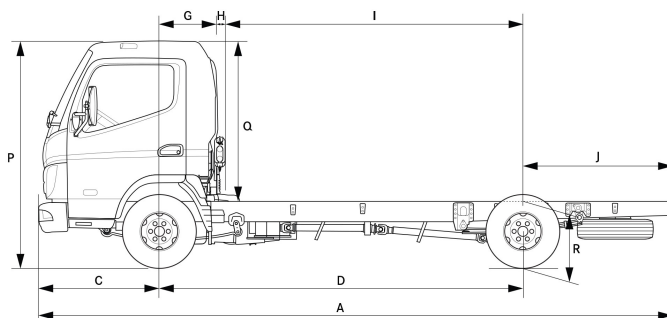
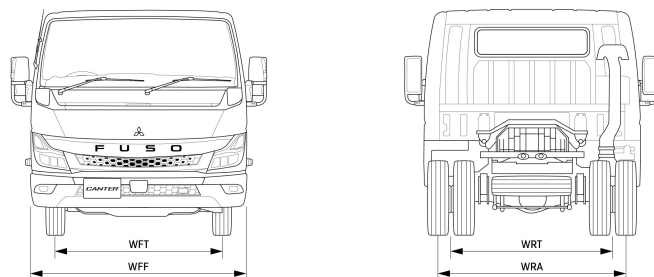

Call 1800 033 557

or visit fuso.com.au

Unless specified in writing herein the accessories, applications, bodies or equipment depicted in this are for illustration purposes only and may not be available from Daimler Truck Australia Pacific Pty Ltd. ABN 86 618 413 282 DTAuP. No representation or warranty whatsoever is given in relation to any accessories, applications, bodies or equipment or suitability of same that are shown herein that may be manufactured, supplied or fitted by a party other than DTAuP. DTAuP reserves the right without notice or obligation to discontinue or make changes to the colour, designs, materials and specifications of the products and options referred to herein at any time. For the most current information and in order to ascertain which accessories, applications, bodies and equipment are available from DTAuP please contact your authorised FUSO dealer. Fuso is a registered trademark of Daimler Truck Australia Pacific Pty Ltd. Copyright DTAuP. Reproduction in whole or part prohibited without written approval. Valid from 19-Mar-24.