

# CANTER

FUSO

## CANTER 515 CREW CAB

4X2 / CITY CAB / DUONIC DCT



**OUR SAFEST CANTER EVER WITH AEB, LDWS AND ESP STANDARD  
CLASS LEADING 30,000KM SERVICE INTERVALS.**

GVM

4,495<sub>KG</sub>

GCM

7,995<sub>KG</sub>

Power/Torque

110<sub>KW</sub> / 370<sub>NM</sub>

- Can be driven on a passenger car licence

FUSO

# CANTER SPECIFICATIONS

## MODEL

- A 4x2 515 City Crew Cab MWB 6 Sp. Duonic AMT (FEA21ER3WFBC)
- B 4x2 515 City Crew Cab MWB 6 Sp. Duonic AMT (FEA21ER3WFAC)

## WHEEL BASE

- 3400mm
- 3400mm

## GVM (optional)

- 4,495kg
- 4500kg

## GCM (optional)

- 7,995kg
- 8000kg

## Engine

Engine Version	FUSO 4P10-T4 Diesel
Configuration	4 Cyl. In-line DOHC, 4-Valve
Type	Variable Geometry Turbo Charged Air to Air Intercooled
Displacement	3 litre (2998cc)
Bore	95.8mm
Stroke	104mm
Power (DIN)	110kW @ 2840~3500 rpm
Torque (DIN)	370Nm @ 1350~2840 rpm
Maximum Engine Speed	4100 rpm
Compression Ratio	17.5:1
Cooling System / Oil Cooler	Water cooled, 14.1L capacity/ Plate type engine oil cooler
Air Cleaner	Paper Element Type with Restrictor Indicator. Vertical Intake Mounted on Clean Air Side (RH)
Emission Control	Diesel Particulate Filter (DPF) Exhaust Dash Display DPF Status 0~9 (Empty~Full) Parked Regeneration possible from 7~9
Emission Level	ADR 80/03 & EEV rated Enhanced Environmentally-Friendly Vehicle Euro 5

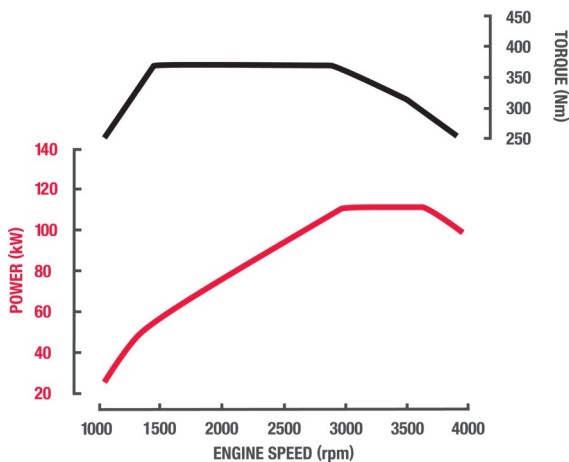

## Fuel

Injection System	Bosch Common Rail Direct Injection Bosch Piezo Technology Injectors
Tank Type	Rectangular Steel Tank with Locking Cap
Fuel Capacity *	100 Litres
Filtration	Filter with Water Separator and Indicator Sensor
Notes	*Max Fill to approx 95% of Air Capacity

## Cooling

Fan Drive	Thermo modulated continuous control (Viscous)
Radiator	Corrugated Fin with Expansion Tank

## Electrical

Voltage	12V Negative Earth
Battery Capacity	1x12V, 70Ah/5hr
Battery Specification	115D31L x2
Headlamp Type	Halogen
Headlamp Capacity	2x55W/60W
Body Builder Harness	Yes*
Notes	*Standard from October 2021 build

## Clutch

Clutch Model	Fully Automated Dual Clutch (no clutch pedal)
Type	Dual Clutch (Wet Multi-plate)

## Transmission

Version	FUSO Duonic M038S6
Type/Speeds	6 Speed Dual Clutch with Auto and Manual Modes
Features	Virtually Instant Gear Changes In-Dash Gear Lever with Park Brake Position ECO Mode to Minimise Fuel Usage
Ratios	1st: 5.397 2nd: 3.788 3rd: 2.310 4th: 1.474 5th: 1.000 6th: 0.701 Rev. 5.397
PTO Opening	LH Side

## Front Axle

Axle Version	FUSO F200T
Type	Independent Front Suspension
Capacity *	2300kg
Notes	*See MAX LOADING for vehicle capacity.

## Front Suspension

Type	Double Wishbone Independent Front Suspension with Coil Springs and Double Acting Shock Absorbers
Size	N/A

## Rear Axle

Type	Full Floating Banjo Type
Axle Version	FUSO R030T
Capacity*	3800kg
Ratio	4.444:1
Notes	*See MAX LOADING for vehicle capacity.

## Rear Suspension

Type	Steel Suspension
Details	Parabolic Leaf with Double Acting Shock Absorbers
Size Main Leaves	1100x70mm
Size Helper Leaves	N/A

## Max Loading

Front	2300kg
Rear	3800kg
Total	<b>A</b> 4495kg <b>B</b> 4500kg

## Options

## Steering

Type	Rack & Pinion
Steering Column	Tilt/Telescopic Adjustable
Power Assist	Standard



# CANTER SPECIFICATIONS

## MODEL

**A** 4x2 515 City Crew Cab MWB 6 Sp. Duonic AMT (FEA21ER3WFBC)  
**B** 4x2 515 City Crew Cab MWB 6 Sp. Duonic AMT (FEA21ER3WFAC)

## WHEEL BASE

3400mm  
 3400mm

## GVM (optional)

4,495kg  
 4500kg

## GCM (optional)

7,995kg  
 8000kg

Brakes		
Type	Hydraulic Dual Circuit with Front and Rear Discs Single Calliper Front and Rear	
Size Front	<b>A</b> 219x28mm	<b>B</b> 276x28mm
Size Rear	<b>A</b> 219x28mm	<b>B</b> 276x28mm
Features	<b>A</b> ABS plus EBD (Electronic Brake Distribution) Active Emergency Braking System (AEBS) Electronic Stability Program (ESP) Exhaust Brake Brake Priority System Electronic Brake Wear Sensors (From Aug 20 build)	<b>B</b> ABS plus EBD (Electronic Brake Distribution) Exhaust Brake Brake Priority System Electronic Brake Wear Sensors (From Aug 20 build)
Park Brake	Transmission Mounted	

Wheels & Tyres	
Wheel Type	7 x Single Piece Disc Rims (Including Spare)
Wheel Size	15x5J-115
Wheel Stud Pattern	5 Stud 208 PCD
Tyre Size All	195/85R15 113/111
Spare Tyre Carrier	Provided

Chassis	
Type	Reinforced Tapered Channel
Size	188x60x4mm
Width	699mm
Tensile Strength	440 MPa

Instruments		
Gauges	Speedometer with Odometer Tachometer Fuel Level Water Temperature	
Colour Information Display	<b>A</b> Fuel Consumption DPF Bar Chart from 1-9 Water Temperature Lane Departure Warning Maintenance Reminder System Tripmeters	<b>B</b> Fuel Consumption DPF Bar Chart from 1-9 Water Temperature Maintenance Reminder System Tripmeters

Multi-Media Package		
Satellite Navigation	Maps with heavy vehicle weight, length, height & hazardous material selectable restrictions with 3 years of Map updates	
Colour Display	<b>A</b> 7 inch LCD with touch screen control	<b>B</b> 6.1 inch LCD with touch screen control
Phone Connectivity	Bluetooth® hands free	
Audio Visual Entertainment	<b>A</b> Bluetooth® music streaming compatible Digital radio DAB+ (also AM/FM for areas not covered by DAB+) USB & 3.5mm/AUX port	<b>B</b> CD/DVD player and Digital radio DAB+ (also AM/FM for areas not covered by DAB+) USB
Reversing Camera Compatible	<b>A</b> Display can accept up to 5 cameras#	<b>B</b> Display can accept up to 3 cameras#
Optional Accessories (available at additional cost)	Rear Mounted Parking Sensor Kit High or Low Tyre Pressure Monitoring System	
Notes	<b>A</b> # Cameras available through spare parts	<b>B</b> # Cameras available through spare parts

Standard Features		
Airbag(s)	Dual Air Bags and Seat Belt Pre-Tensioners (Driver & Far Side Passenger)	
Active Safety Features	<b>A</b> ABS plus Electronic Brake force Distribution System (EBD) Advanced Emergency Braking (AEBS) Anti-Slip Regulator (ASR) Electronic Stability Program (ESP) Lane Departure Warning System (LDWS)	<b>B</b> Antilock Braking Brake force Distribution System
Electronic Stability Program (ESP)	<b>A</b> Yes	<b>B</b> No
Idle Stop Start (ISS)	No	
Cruise Control	Yes	
Hill Start System	Yes	
Cab Cooling & Heating	Air Conditioner / Heater / Demister. Rear crew air conditioner and heater with separate control	
Accessory Power Driving	12V Accessory Power Outlet / Cigar Lighter Fuso Multimedia Unit Keyless Central Locking Electric Windows (front only) Cup Holders (2)	
Storage	Dual Overhead Storage Pockets Lockable Storage Under Rear Crew Seats In-Dash Centre Document Storage Door Storage Pockets Dash Storage Tray (1 DIN)	
Cab: External	Door Side Impact Beams (front only)	
Chassis	Reverse Warning Buzzer Factory Reverse Camera with Infrared Display and Audible Pickup (Supply only in Cabin with Cab Chassis)	

# CANTER SPECIFICATIONS

## MODEL

A	4x2 515 City Crew Cab MWB 6 Sp. Duonic AMT (FEA21ER3WFBC)
B	4x2 515 City Crew Cab MWB 6 Sp. Duonic AMT (FEA21ER3WFAC)

## WHEEL BASE

3400mm
3400mm

## GVM (optional)

4,495kg
4500kg

## GCM (optional)

7,995kg
8000kg

Cab Features	
Type	All Steel Forward Control Fixed Cab
Cab Structure	N/A
Mounting	6 Point Isolated Rubber
Additional Engine Access	Removable Engine Access Panel
Colour	Natural White
Windscreen Wipers	2 Speed + Intermittent Cycle with Integrated Washer Nozzles
Rear Vision Mirrors	1 x Internal 2 x External Convex (ECE 46) - Heated
Seating Capacity	6
Seat Belts	<b>A</b> 4 x Lap Sash Belts and 4 x Lap Sash Belts and Head Rests for Outside Seating <b>B</b> 4 x Lap Sash Belts and 4 x Lap Sash Belts and Head Rests for Outside Seating 2 x Lap Belts for Centre Seat 2 x Lap Belts for Centre Seat Driver Seat Belt Warning (From Aug 20 build)
Seat (driver)	Fixed Reclining LH Arm Rest & Lumbar Support
Seats (passenger)	Flat Folding, 2 Passenger Bench for Front Passengers
Seats (crew cab rear)	Low Back Bench Seat

Service Intervals	
Interval*	30,000km or 12 Months (whichever occurs first)
Notes	* based on normal operating conditions and may be reduced when operating under severe conditions.

Warranty	
Basic/Powertrain	5 Years or 200,000kms (whichever occurs first)
Cab Perforation/Anti Corrosion	5 Years

Performance	
Turning Circle (kerb to kerb - metres)	11.8
Road Speed (km/h) at Max Engine Speed	145
Engine Speed (rpm) at 100km/hr (top gear)	2388
Gradeability at Rated GVM (theoretical)*	45%
Notes	*This is theoretical performance only. Actual performance may vary under different conditions

Mass estimated*		
Front*	<b>A</b> 1515kg	<b>B</b> 1550kg
Rear*	<b>A</b> 665kg	<b>B</b> 615kg
Total*	<b>A</b> 2180kg	<b>B</b> 2165kg
Notes	* Mass (est.) includes oil and water but excludes spare wheel, tools & fuel. Weights provided are subject to 3.5% variation (+/-)	

Dimensions mm	
WFF (Width Front Fender) (mm)	1695
WRA (Width Rear Axle) (mm)	1869
WRT (Width Rear Track) (mm)	1435
Width Frame (mm)	699
A - Length Overall (mm)	5785
C - Front Overhang (mm)	990
D - Wheelbase (mm)	3400
G - Front Axle to Rear of Cab (mm)	1475
H - Rear of Cab to Rearmost Item Behind Cab (mm)	130
I - Rearmost Item Behind Cab to Rear Axle (mm)	1795
J - Frame, Rear Axle to End (mm)	1395
P - Height Cab to Ground (mm)	1995
Q - Height Cab to Frame (mm)	1374
Hf - Height Front Frame to Ground (mm)	630
Hr - Height Rear Frame to Ground (mm)	729

Body Builder's Notes	
Notes	Chassis reinforcement must be utilised for Tipper/Demountable type body configurations. To conform with ADR 13/00 and 14/02 (lighting/mirror requirements) the following must be adhered to at body installation. - If overall width exceeds 2.1 metres and other than flat type or tipper body is fitted, rear end-outline markers must be installed. - If overall length exceeds 6.0 metres, side reflectors must be installed. - If overall length exceeds 7.5 metres and width exceeds 2.1 metres, side marker lamps must be installed. - If overall width is less than 1.9 metres (for city cab) or 2.2 metres (for wide cabs), the mirrors must be modified to project not more than 230mm. To conform with ADR 42/04 (General Safety), rear wheel guards must be fitted to the vehicle.

# CANTER SPECIFICATIONS

## MODEL

- A 4x2 515 City Crew Cab MWB 6 Sp. Duonic AMT (FEA21ER3WFBC)
- B 4x2 515 City Crew Cab MWB 6 Sp. Duonic AMT (FEA21ER3WFAC)

## WHEEL BASE

- 3400mm
- 3400mm

## GVM (optional)

- 4,495kg
- 4500kg

## GCM (optional)

- 7,995kg
- 8000kg



**Call 1800 033 557**

or visit [fuso.com.au](http://fuso.com.au)

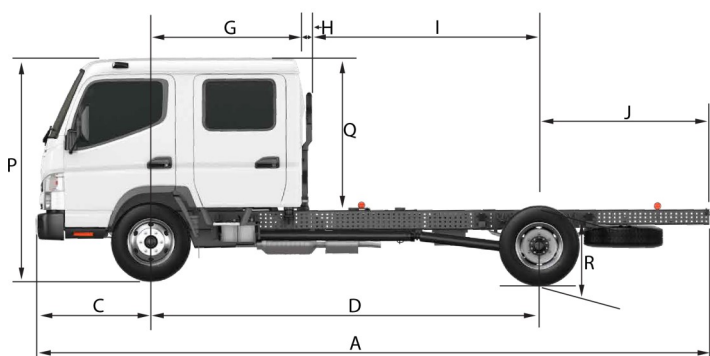

Unless specified in writing herein the accessories, applications, bodies or equipment depicted in this are for illustration purposes only and may not be available from Daimler Truck Australia Pacific Pty Ltd. ABN 86 618 413 282 DTAuP. No representation or warranty whatsoever is given in relation to any accessories, applications, bodies or equipment or suitability of same that are shown herein that may be manufactured, supplied or fitted by a party other than DTAuP. DTAuP reserves the right without notice or obligation to discontinue or make changes to the colour, designs, materials and specifications of the products and options referred to herein at any time. For the most current information and in order to ascertain which accessories, applications, bodies and equipment are available from DTAuP please contact your authorised FUSO dealer. Fuso is a registered trademark of Daimler Truck Australia Pacific Pty Ltd. Copyright DTAuP. Reproduction in whole or part prohibited without written approval. Part Number TSC113B-SSV1. Valid from 05-Nov-21.